

Product data sheet



Information

Designation	Extending straight curtain rail, 620 à 1020 mm, Chrome and nickel-plated Brass, tube Ø 16 mm
Reference	004911



Product advantages

- + Corrosion resistant warranty.

Description

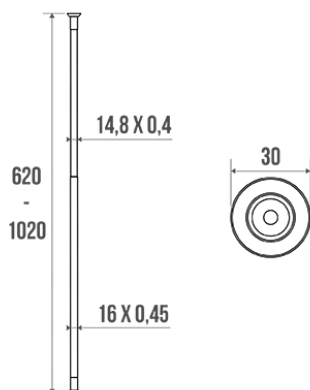

Straight tube Ø 16 x 0,5 mm.
Cannot be shortened.
After positioning the flanges on the wall, adjusting the width of the tube for screwing / unscrewing.

Wall fixings not included.

Technical characteristics

Finish	Chrome and nickel-plated
Dimensions	620 to 1020 mm
Diameter Ø	16 mm
Material	Brass
Gross weight	0.230 kg
Packaging	Plastic protection bag + Hanger for display
Made in France	yes
Maintenance	yes
Guarantee	10 years
Gencod	3563390049112
Custom code	7418200090
Technical sheet	No technical sheet available

Fixing and maintenance advices

No particular recommendation for the fitting.

Fiche produit mise à jour le : 07/05/2024